

Adient  
NA Regional Supplier Standards Manual  
Tooling and Equipment  
Metal Stamping Dies – North American Tooling Standards

July 2025

---

**1. Purpose**

- 1.1. The purpose of this procedure is to assure when a new die is being manufactured for Adient that the construction and performance is consistent with the guidelines set forth in the Tool specifications and expectations of the company.
- 1.2. Tool Rating Measurables
  - 1.2.1. Tool to be delivered on time
  - 1.2.2. Tool to be 100% complete at delivery
  - 1.2.3. Minimal adjustments during run-off's (4hrs allotted time)
  - 1.2.4. Part fits Gage and has clean CMM Layouts
  - 1.2.5. Meet Adient PPM Goals
  - 1.2.6. Meet 77% Utilization Goals
  - 1.2.7. Minimum Cost, Maximum Quality of Tools
  - 1.2.8. Build to Maximum Efficiency
  - 1.2.9. Meet set-up time
  - 1.2.10. Tools must meet all Safety guidelines

**2. Scope**

- 2.1. This Adient Die Specification applies to dies to be built to run at Adient stamping facilities in North America as well as Adient stamping suppliers in North America unless Third Party Stamper Standards are approved by Adient AME Tooling Team (i.e. Part Suppliers (PS)).

**3. Responsibility**

- 3.1. The Tooling Integrator is responsible for ensuring Adient die specifications are met before, during, and after die construction.
- 3.2. Any exceptions to Adient North American Stamping Die Standard must be submitted and approved in writing by Adient.

Adient  
NA Regional Supplier Standards Manual  
Tooling and Equipment  
Metal Stamping Dies – North American Tooling Standards

July 2025

---

- 3.3. This document will be used as a checklist during the tool buy-off procedure. Each item will be initialed if the standard is met in the tool. If the standard is not met in the tool, approval must be provided by the Adient ATE (Advanced Tooling Engineer). Otherwise, the buy-off cannot be completed until the standards are fulfilled.
- 3.4. All tools must be warranted for craftsmanship and production capability for a minimum of 50,000 strokes run in full auto. Tools will be tagged by vendor as warranted until the 50,000 strokes are complete. In the event of a die crash, Adient will leave the last strip in the tool and/or provide pictures of the damaged tool to the vendor upon a warranty claim. A report of how many strokes the tool has completed to date will also be provided.
- 3.5. Adient will provide tryout material. Tool must be run-off with material supplied by Adient. Tool vendor is required to communicate the tryout material specifications, dimensions, and timing requirements to the Adient Material Manager. Confirmation from the Adient Material Manager and ATE must be received and documented that all deliverables can be met. Any deviation from this requirement must be signed off by the Adient ATE.
- 3.6. Adient is to receive progress reports with a summary page (see Adient template) on the 10<sup>th</sup> and 25<sup>th</sup> of each month; Adient reserves the right to request a progress report between these times.
- 3.7. All documents provided by the (GLOBAL TOOLING SUPPLIER) to Adient/CM must be supplied in English.
- 3.8. All dies will be designed and built to metric standards. Identify that the tool was built to metric standards by stenciling “Metric” on both sides of the tool, top and bottom.

#### **4. Tool Build Process Requirements**

##### **4.1. General Requirements**

- 4.1.1 A part print and cad model will be supplied for the design. It is the responsibility of the tool designer to compare the part print and CAD model and report any discrepancies to the tooling engineer.

Adient  
NA Regional Supplier Standards Manual  
Tooling and Equipment  
Metal Stamping Dies – North American Tooling Standards

July 2025

---

- 4.1.2 Required Minimum Gross Tool Operating Speeds:
- 4.1.2.1. Unless otherwise approved in writing, dies must be designed and built to run **above** defined minimum strokes per minute (SPM) defined by quoted SPM to customer. Adient Purchasing to provide this information.
  - 4.1.2.2. Die run-offs will require die to be run at the defined SPM for the 300-hit run in the (GLOBAL TOOLING SUPPLIER)'s specified press and for 90 continuous minutes at the Adient/CM stamping facility.
  - 4.1.2.3. Mechanical movements or operations in the tool must not be limiting factor. If problems are anticipated, these must be notified to Adient in writing with explanations for the concerns.
  - 4.1.2.4. Tool Design must not to be limiting factor on achievable SPM on tool
- 4.1.3 (GLOBAL TOOLING SUPPLIER) must perform a Multi-step Forming Simulation. If a potential failure exists as the result of the simulation, the (GLOBAL TOOLING SUPPLIER) must work with Adient Engineering and ATE to resolve all potential forming issues before 50% Die Process Validation Approval. All forming simulations must be performed using inputs that are provided by Adient. Adient Simulation Standards and Tool Kit are to be used. Simulation Standards are updated by Adient annually.
- 4.1.4 Written approval from Adient must be obtained by the (GLOBAL TOOLING SUPPLIER) for any part the (GLOBAL TOOLING SUPPLIER) pleads does not require a forming simulation.
- 4.1.5 Bypass and Stamp locations need to be approved by Adient Prior to 100% design. A CAD model must be submitted with the PDF of the Approval form to Adient Engineering and the Adient Tooling Engineer.

Adient  
NA Regional Supplier Standards Manual  
Tooling and Equipment  
Metal Stamping Dies – North American Tooling Standards

July 2025

---

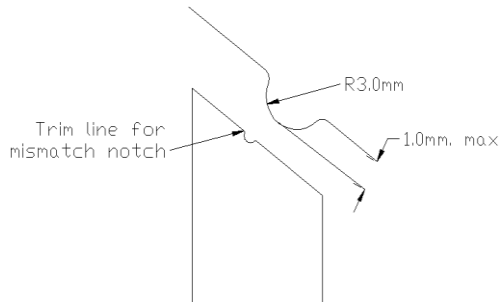

- 4.1.6 The Adient Tool Data Sheet must be provided upon 100% design review. Any changes in the tool design after the 100% design review must be resubmitted promptly. These data sheets need to be provided to the Plant Engineer Coordinator, ATE, and the Tooling Buyer.
- 4.1.7 Prior to 50% design approval the (GLOBAL TOOLING SUPPLIER) must provide the calculated tonnage required to make the intended product. The calculated tonnage must not exceed 80% of the press rated tonnage for the intended production press. It is the responsibility of the (GLOBAL TOOLING SUPPLIER) to not exceed the press tonnage at Buy-off at the Adient/PS facility.
- 4.1.8 If the calculated tonnage exceeds 80% of the press rated tonnage for the intended press, the (GLOBAL TOOLING SUPPLIER) must obtain approval to proceed with design past 50% design approval. Upon approval, the (GLOBAL TOOLING SUPPLIER) is responsible to not exceed the actual press tonnage agreed upon by Adient at Buy-off at the Adient/PS facility. The Adient presses monitor all (4) corners of the press for tonnage. Therefore, the die must not overload any one corner of the press to successfully complete Buy-off.
- 4.1.9 All designs are to be approved by Adient prior to die construction. The (GLOBAL TOOLING SUPPLIER) must provide enough time to perform a proper design review and give one week notice before designs need to be approved. It is the responsibility of the (GLOBAL TOOLING SUPPLIER) to manage the design reviews to maintain program timing. (GLOBAL TOOLING SUPPLIER) will set up meetings to review Simulation and Strip, 50% Design review, and 100% Design review. All Adient Tooling Engineers are to be invited to the meeting as well as Plant Engineers receiving the Tool. 24 Hour notice should be given when setting up a design review.

Adient  
NA Regional Supplier Standards Manual  
Tooling and Equipment  
Metal Stamping Dies – North American Tooling Standards

July 2025

---

- 4.1.10 All die designs must be supplied in 3-D with 100% CAD models, surface data, bill of materials with perishable items identified and strip layout. The strip layout must have each station defined. Tools must be designed in 3D.
- 4.1.11 Required data format for 2D detail prints is “DWG” or “DXF”. Required data format for 3D design is “.stp”.
- 4.1.12 Details must have a 2D detail print showing all holes and dowels.
- 4.1.13 2D detail prints, CAD and BOM must be provided to the Adient stamping plant and Adient ATE after tool buy-off:
  - 4.1.13.1 Surface data used to create and cut any detail that is 3D. These details included, but are not limited to trim steels, form steels, pierce details: i.e. anything cut in 3D).
  - 4.1.13.2 Detail drawings for all cutting, piercing, form inserts and Pressure Pad window inserts. These drawings must be fully dimensioned.
- 4.1.14 Detail drawings required for all cutting, form inserts and Pressure Pad window inserts. Drawings must be fully dimensioned
- 4.1.15 An itemized bill of materials (BOM) must be supplied for all perishable purchased items. This BOM must also include the supplier contact information and part number.
- 4.1.16 All die details to be stamped with detail numbers and material specifications.
- 4.1.17 Working parts of the die may not extend beyond the peripheral limits of the die-set without written authorization from Adient. This should be captured in the die design sign-off forms.
- 4.1.18 All dies to run “Right” to “Left” unless specified otherwise. Exceptions will be documented and agreed to prior to 100% design approval.
- 4.1.19 Two outboard hardened stock guides are required on progressive, and transfer dies. These guides must be at least 150mm long with an adjustable guide on the front of the die to accept 6mm wider stock. Cylindrical slotted stock guides are not allowed in dies unless authorized in writing by Adient.

Adient  
NA Regional Supplier Standards Manual  
Tooling and Equipment  
Metal Stamping Dies – North American Tooling Standards

July 2025

---

- 4.1.20 All coil fed dies to have pitch notch trim on one side of strip capable of trimming 3mm unless written exception is granted by Adient ATE. Dies with stock below 1.5mm and/or wider than 400mm will have a pitch notch trim on both sides of the die. Dies are to be built so the steel is against pitch notches when in proper progression. Coil fed dies (including transfer dies) with a pitch greater than 200mm will require an alternative method of positive strip location other than what has been defined herein. This must be proposed, defined, and approved by Adient at the tool design review.
- 4.1.20.1 The pitch notch is to be used as the “first hit” indicator. If the “first hit” is other than the notches, a start line must be scribed in the die and a spring-loaded first hit pin should be included. If coil is wider than 400mm, two first hit pins should be included.
- 4.1.20.2 If an incomplete part or a slug is generated when a new strip is started, a sample part or slug must be painted red and riveted to the die shoe at the position it must be removed from the die.
- 4.1.20.3 Pilot holes and pitch notch may be pierced before the strip is against the Hard Stops after the 153mm guides. No other work can be done before the Hard Stop.
- 4.1.21 Provisions in the tool (ex. Lifters in the lower die) must be accommodated to feed the initial strip for set-up through the tool unassisted. If it is identified during design that the product does not lend itself to incorporate this feature in the tool, this must be identified in the Adient Design Review Approval forms and signed off by a Adient representative.
- 4.1.22 All designs must have scrap going through shoe and part off end of tool. A signed approval from Adient will be required for any deviation. A fixed “part out” chute must be supplied with the tool designed for the designated press intended to run the tool. Transfer tools to be supplied with scrap slides directing scrap to bolster openings or scrap conveyors. This must be defined by the 50% design review.

Adient  
NA Regional Supplier Standards Manual  
Tooling and Equipment  
Metal Stamping Dies – North American Tooling Standards

July 2025

---

- 4.1.23 All dies are required to have interchangeable stamp retainers for both part number, and manufacturing Julian date located in the coil fed section of the upper die set. If the stamps are required to be in lower die set, a quick-change type under coil must be used. Reference Figure 6 for quick change design. Deviations require Adient sign off and approval.
  - 4.1.23.1 Adient Engineering must approve stamp location and type if not specified on part print. This is to be identified on the Bypass approval form.
  - 4.1.23.2 Two out identical part dies must have cavity identifiers (i.e. F & B, L & R, X & Y)
  - 4.1.23.3 Use Argon brand stamps or equivalent taper lock type. Equivalents must fit properly in Argon Retainer, No Home-made Stamps.
  - 4.1.23.4 Use 9 position holders
  - 4.1.23.5 Date and part number stamps must be in place during any early part builds and tool buy-off runs.
- 4.1.24 When product is designed with a hem, (3) operations will be required in the tool to make the hem. Any deviation from this standard will require sign-off from a Adient representative and identified on the Adient Design Approval forms.
- 4.1.25 Die weight may not exceed a total weight over 30 tons. The upper die may not exceed 12 tons. The total weight of the tool must include parallels and change plates. Any die design that exceeds the weight requirement must be brought to Adient's attention. Resolution to the weight issue must be defined on the tool design review sign-off forms. Preliminary weight calculations on all tools must be provided at the first design review.
- 4.1.26 At 100% design review, scrap removal system must be reviewed and approved by Adient. The complete die with QDC plates, "dog bones", or any other peripheral items attached to the die must be considered with a scrap removal system in place to avoid all obstacles to allow unimpeded removal of scrap.
- 4.1.27 Cast die steels are not permitted for cutting steels.
- 4.1.28 Cast FCS 50 or GM 190 is permitted in forms as "horns".

July 2025

---

- 4.1.29 Eifeler DUPLEX-VARIANTIC®-1000 coating to be used or equivalent for all details identified during design. Dual Phase Material requires coating of Punches and Forms at minimum. All details that “Wipe” or have high wear require coating. When using steel on steel healing Coating may be required.

## **4.2 General Build Requirements**

- 4.2.1 Sharp edges should be broken on all blocks and plates to avoid injury to personnel (i.e. die blocks, removable holders, Pressure Pads, windows, die shoe, parallels, QDC plates, etc.)
- 4.2.2 Dies will be supplied painted. Color to be defined by the stamping plant. All sections of the die that contact the product must be unpainted on the contact surfaces. Scrap chutes and guards will be painted safety yellow.
- 4.2.3 Upper die shoe weight should be identified on the upper. Total die weight should be identified on the lower. Stencil on two sides with 50 mm high letters. Stencil part number on upper die shoe. Stencil “Front Side” and “flow direction” on the die. Removable chutes must have the die number on them for tracking purposes.
- 4.2.4 Die storage blocks required on all tools to be discussed during design review. If no agreement Nitrogen cylinders will be used.
- 4.2.5 HOLO-KROME Bolts or equivalent must be used.
- 4.2.6 No Flat Head Bolts. No low Head Bolts.
- 4.2.7 Dowels are to be Pull Dowels. No Blind Dowel holes allowed.
- 4.2.8 Jack Screw Holes should be the same thread as the Bolts used to install the Detail.
- 4.2.9 Minimum thread engagement must be 2 times the diameter of the bolt for Cast tools 1.5 X Dia for Plate tools.

July 2025

---

- 4.2.10 All form or cutting steels welded during the die development must be replaced by the (GLOBAL TOOLING SUPPLIER) in time for the Adient/CM plant buy-off.
- 4.2.11 No Graphite impregnated Wear Plates, or Bushings.

### **4.3 Forms and Cutting Steels**

- 4.3.1 Cutting and Forming on the same section requires written approval by Adient. (GLOBAL TOOLING SUPPLIER) must clearly identify during design review phase and are responsible for obtaining written approval from Adient.
- 4.3.2 All die sections are to be face mounted for removal in press. Sections to include jack screws.
- 4.3.3 All one-sided trims must be heeled, with the heel entering the die before the punch contacts the material. Heel blocks must not be steel on steel. Ampco type material must be used on one face. Heel blocks must be keyed or pocketed to die shoe. Lower sections must be keyed or be pocketed on the opposite side of trim area. (Figure 3.). Deviations require Adient sign off and approval.
- 4.3.4 All cutting and form sections are to be bolt & dowel replaceable with 100% cad data and dimensioned 2D drawings to be supplied by Global Tooling Integrator.
- 4.3.5 All sections are to have the bolt & dowel patterns off-set to prevent the section being installed improperly.
- 4.3.6 Dowels in an individual section must all be the same size.
- 4.3.7 Dowels should be press fit into die shoe and slip fit into sections. Provide through hole to remove dowel pins. Absolutely no blind dowel holes.
- 4.3.8 Bolted sections and punches should have threaded jackscrew holes between or adjacent to the dowels. Extractor threads should be the same size as the retaining bolts in that section.
- 4.3.9 Larger sections must be keyed or pocketed for greater support and ease of locating.

Adient  
NA Regional Supplier Standards Manual  
Tooling and Equipment  
Metal Stamping Dies – North American Tooling Standards

July 2025

---

- 4.3.10 All sections heavier than 100 pounds to have handling hole to allow for removal of section by overhead hoist. Large sections must also have wedge slots or jack screws to assist in loosening the section.
- 4.3.11 Die sections must have a minimum wall thickness of 10mm. If part design does not permit, a product change request must be submitted in writing to Adient. If product change is not approved the area in the tool with this condition must use an insert that can be changed in the press. This condition must also be approved and signed off by Adient during the design review process.
- 4.3.12 Provide clearance holes through the die shoe for all slugs and pilot holes.
- 4.3.13 All sections are to be bolted such that when the section is sharpened and shimmed the die clearance and longevity of the trim steel is not affected.
- 4.3.14 All cutting sections must have 10mm diameter minimum socket head cap screws and thread engagement must be 2 times screw diameter.
- 4.3.15 All lower die sections to be 50mm thick minimum.
- 4.3.16 All upper die trim punches to have a hardened backing plate 6mm thick minimum.
- 4.3.17 Top of socket head cap screw to be pocketed 10mm below the die life of die section to allow for sharpening.
- 4.3.18 Blanking and trimming die sections to have 10mm die life. If not possible or feasible, a written explanation must be identified on design review sign-off forms and approved by Adient.
- 4.3.19 Die sections must be undercut below the “die-life” land. Wire burned sections may use tapered undercuts.
- 4.3.20 All pierce buttons to be headless and key retained for easy removal. In a perforation pattern too small for inserts, use wire burned sections instead of buttons. Cam Pierces to be Inserts not buttons to allow for adjustments of position.
- 4.3.21 All Buttons must incorporate tapered relief. Standard relief (step relief) buttons should not be used. Slug retention buttons are acceptable when ejectors cannot be used.
- 4.3.22 No cutting steels to be larger than 250mm x 250mm without Adient Approval. Upper trim steel(s) must not exceed 30 lb. per section.

Adient  
NA Regional Supplier Standards Manual  
Tooling and Equipment  
Metal Stamping Dies – North American Tooling Standards

July 2025

---

- 4.3.23 Trim steel mismatch burrs on trim edges should be prevented with notches, but only by request to the Adient Engineering Manager or Tooling Engineer who must sign part prints to show and approve the locations (See Figure 2).
- 4.3.24 If a hole is not direct pierced, a Cam must be used to achieve tolerances of 1.0mm True Position or less. If a surface profile zone is not in die plane and has a profile tolerance of 0.75mm or less, a cam must be used to restrike. If a trim line is not in die plane and has a profile tolerance of 0.75mm or less, a cam must be used to trim.
- 4.3.25 3-D cutting sections must be avoided. If approved by Adient in the design review, CAD surface models must be provided after buy-off at the (GLOBAL TOOLING SUPPLIER).
- 4.3.26 All details must have 2 screws minimum to fasten to die set.
- 4.3.27 All upper die trim punches to have shear and stagger to reduce tonnage.
- 4.3.28 All upper die trim punches to have slug ejectors.
- 4.3.29 Minimum punch entry is 10mm.
- 4.3.30 All form steels are to be inserted allowing for easy adjustment. (See Figure 1)
- 4.3.31 Form sections must be direct mounted to the upper die shoe. Form steels may only be mounted on the Pressure Pads in special cases and must be approved by Adient at the 50% design review. This must be identified on the design review sign-off sheets with an Adient signature. In this case, the Pressure Pad must be made to bottom out onto blocks in the upper die. Form steels mounted on Pressure Pads require Pressure Pad to be guided by pins & bushings and must have bi-directional heel blocks.
- 4.3.32 Form steels working with offset loads must be heeled on the opposite side of the die shoe. Heel area must engage before forming starts by a minimum of 40mm. Heel blocks must not be steel on steel. Dissimilar material must be used on at least one face. Heel blocks must be keyed and/or pocketed to the die shoe.
- 4.3.33 Crash forming is not allowed unless authorized in writing by Adient. This should be identified and signed off in the design review sign-off forms.
- 4.3.34 Draw pads are required for areas where the part is likely to wrinkle or overlap when formed. Pads should be inserted with D2 in High wear

areas and hardened. Pads must have nitrogen springs (individual cylinders or manifold) plumbed to a common gauge with charge valve. A Pressure Monitor sensor must be installed whenever Nitrogen cylinders are linked together. Bolts and dowels must not extend into the working area of the draw pads. Adequate gauging must be provided to locate the part correctly into the draw station before it is gripped by the pads. All Pads require adjustable standoffs.

- 4.3.35 Any draw beads and pad stand-offs must be shim adjustable in the press.
- 4.3.36 Draw pads must be hand finished to compensate for material thickening. Coating is required in high wear areas.
- 4.3.37 All large or closed draw forms to have vents to prevent parts from sticking and to vent air.
- 4.3.38 All trim steels must be removable inserts to allow for sharpening and replacing in the press. All sections must be mounted to CR or HR plate steel.

#### **4.4 Steel Types, Coatings and Surface Treatments**

- 4.4.1 All cutting steels must be a minimum of A2 when the product design intent requires material 3.0mm and thinner, S7 cutting steel for any material thicker than 3.0mm.
- 4.4.2 Commercial ball lock punches must be made of M2 steel. For tools that have a yearly planned volume that exceeds 1 million and/or have a material specification for the product with SAE J2340 420XF (JIS G3135 SPFC 540) or harder must come supplied with special wear resistant punches. Material type and/or coating must be approved by Adient in writing at design review.
- 4.4.3 Absolutely no welds or fitted plugs on cutting steels.
- 4.4.4 All forming & drawing steels are to be D2 tool steel or better.
- 4.4.5 Coating for draw pads is only required in high wear areas. Where coating maybe required, draw pads are to include hardened inserts mounted in 4140 pad retainer which will allow Duplex Variantic coating as needed.
- 4.4.6 All extrusion sizing punches must be coated.

Adient  
 NA Regional Supplier Standards Manual  
 Tooling and Equipment  
 Metal Stamping Dies – North American Tooling Standards

July 2025

International Material Equivalency					
Classification	DIN	AISI / SAE USA	GM	JIS Japan	ISO European
<b>Tool Steel</b> (High alloy tool steel)	1.2363	A2	A2	SKD 12	X 100 CrMoV 5
	1.2379	D2	D2	SKD 11	X153CrMoV12
	1.2510	O1	O1	SKS 3	
	1.2833	W2	W2	SKS 43	
	1.2333	S7	S7		
<b>Alloy Steel</b> (Low alloy tool steel)	1.0402 / 1.0414 1.0480 / 1.0044	1020	1020	S20C	
	1.1186 / 1.0511	1040	1040	S40C	C40
<b>Alloy Steel</b> (Low alloy tool steel)	1.1206 / 1.0540	1050	1050	S50C	C50
	1.0601	1060	1060	S60C	C60
	1.6523	8620	8620	SNCM220	20NiCrMo2
	1.7225	4140	4140	SCM440	42CrMo4
	1.7228	4150	4150	SCM445	50CrMo4
	1.8159	6150	6150	SUP10	50 CrV 4
	0.6025	G2500	GM-238	Fc 250	EN-JL 1040
	0.6025 CrMo	G3500	GM-241	Fc 250	EN-JL 2050
<b>Cast Iron</b>	0.7040 (GGG40)	D-4512	GM-245	FCD 400	EN-JS 1030
	0.7050 (GGG50)		D-5506		EN-JS 1050
	0.7060 (GGG60)	D-5507	GM-246	FCD 600	EN-JS 1060
	0.7070 (GGG70)	D 6510	GM-338	FCD 700	EN-JS 1070
	GGG70 NiMo	D-7703			EN-JS 2070
<b>Cast Steel</b>	1.2320	0050A	GM-190		
	1.2382	D2	D2	SKD 11	
	1.2358	S7	S7		

Adient  
 NA Regional Supplier Standards Manual  
 Tooling and Equipment  
 Metal Stamping Dies – North American Tooling Standards

July 2025

ELEMENTS	MATERIAL MIN	Surface Treatment / HARDNESS
Cut and trim elements (punch, plate, bush) non-standardized	A2	Hardened HRC 58-60
Bending elements (males and females)	D2	Hardened HRC 62-64
Critical parts (with possible wear problems)	D2	Duplex Variantic Coating
Draw elements, Pressure Pad plates (contact with sheet metal)	D2	Hardened
Draw elements, Pressure Pad plates (contact with sheet metal) for big volume or very thick	D2	Hardened
Guides for console (centering press)	D2	Hardened
Guide ejectors, punch plates, bush plates	D2	Hardened
Pressure Pad Windows (contact with sheet metal)	4140	Hardened
Chutes	Stainless steel channeled sheet	-
Wear Plates	Bronze, or Dissimilar Metal	One side bronze, the other side hardened OR Dissimilar metals coated

#### 4.5 Punches/Pilots/Ball Locks

- 4.5.1 All trimming or piercing less than 25mm x 25mm sections or pierce punches must have Pressure Pad access window and must be removable in the press.
- 4.5.2 Trim Punches that cut only on one side must be heeled, with the heel entering the die before the punch contacts the material. Heel blocks must not be steel on steel, Ampco type material must be used on one face. Heel blocks must be keyed or pocketed to die shoe. (Figure 3.)
- 4.5.3 Preferred mounting method for punches is bolting or heavy-duty ball lock style holders. Punch ball seat location other than increments of 90-degree orientation is not allowed. If needed to Poka-Yoke punches of similar size Adient may allow Headed Punches, this must be agreed upon during the Design review.

Adient  
NA Regional Supplier Standards Manual  
Tooling and Equipment  
Metal Stamping Dies – North American Tooling Standards

July 2025

---

- 4.5.4 Punches of similar size or shape must have different body diameters for error-proofing
- 4.5.5 No punches larger than the body diameter of the Punch. Use EDM Punch in Retainer or as agreed to during Design review.
- 4.5.6 Smaller shaped cutting punches may be mounted in several ways, as most appropriate for the punch shape and space available in the die. The method selected must be approved by Adient at design review.
  - 4.5.6.1 Mounted in a quick-change holder
  - 4.5.6.2 Heeled into a special punch holder
  - 4.5.6.3** In-press accessible footed punches preferred. Alternative option with approval would be held into wire burned punch holder with hardened washer (minimum 6 mm thick) and screw clip. Minimum 10mm screw.
  - 4.5.6.4 Direct retaining bolts.
  - 4.5.6.5 Taper locking punches in retainers are not allowed.
  - 4.5.6.6 Minimum of (2) bolts per section required.
- 4.5.7 All punches require slug shedders unless punch size/shape will not permit. When the size/shape will not permit a slug shedder, another mechanical means must be used to ensure slugs do not pull out of lower die (I.E. – slug retention buttons).
- 4.5.8 All hole diameters to be pierced between nominal and the high limit of the hole tolerance. If hole tolerance is as narrow as +/- 0.05mm, build to nominal.
- 4.5.9 If a hole being pierced is less than 2 times material thickness, special means must be used to prevent premature punch failure. I.E. – Guided punch or whip sleeve style punches.
- 4.5.10 Piercing is not allowed on an angle over 15 degrees normal to the part surface. For punches smaller than 15mm, the pierce angle may not exceed the punch diameter size in the amount of millimeters to degrees. Under 5mm 5deg. 6-10mm 6deg, 10-14mm 14deg, 15mm-above 15deg any deviations must be approved in writing. Inserts to be utilized in these areas.

Adient  
NA Regional Supplier Standards Manual  
Tooling and Equipment  
Metal Stamping Dies – North American Tooling Standards

July 2025

---

- 4.5.11 All pierce punches must be staggered to reduce tonnage.
- 4.5.12 All pilots to be a minimum diameter of 10mm. Preferred diameter is 13mm.
- 4.5.13 All pilot buttons to be keyed or headed and have 0.05mm clearance per side maximum above pilot diameter. Buttons that are headed must be held by means of inserts avoiding removal of large sections to replace the buttons in the press. If a Pilot hole is in a hardened Trim section Button does not have to be used. No half hole pilot holes between sections.
- 4.5.14 Pilots are to be “positive pick-up” style with a slug clearance hole drilled through the die shoe and parallels
- 4.5.15 Pilots mounted to the Pressure Pads require the Pressure Pads to be guided with Pins and Bushings. Pilots must have ejector pins beside them in the Pad.
- 4.5.16 Transfer tool pilots, or part locators, or lifters in lower die are to be easily removable in press. Pilots are to be held by keys or small inserts with jack screw provisions added.
- 4.5.17 Different size pilots within the same tool must have different body diameters for error proofing.
- 4.5.18 Pilot ejector pins are to be internally contained spring assemblies, no loose springs under the ejector pins
- 4.5.19 Threaded pilots are not allowed. All Pilots should be a purchased component not home-made.
- 4.5.20 Dual Phase Material Requires Coated Pierce Punches.
- 4.5.21 Punch Clearances should follow the guideline below. This is a starting point and may be adjusted during development, Adient AME must be involved in adjusting from the starting point.

Adient  
 NA Regional Supplier Standards Manual  
 Tooling and Equipment  
 Metal Stamping Dies – North American Tooling Standards

July 2025

Yield	Tensile Min.	Grade	<1,0	1,0-1,9	2,0-2,9	>3,0
		Thickness				
820-1100	1180	MP-1180/820	14%	16%	19%	22%
700-900	980	MP-980/700	14%	15%	18%	21%
550-740	980	MP-980/550	14%	15%	18%	21%
485 min	780	MP-780/485	13%	14%	17%	20%
330-440	590	MP-590/330	11%	12%	14%	17%
550-680	620	SAE J2340 Grade 550XF CR/HR	11%	12%	14%	17%
490-590	560	SAE J2340 Grade 490XF CR/HR	11%	12%	14%	17%
420-520	490	SAE J2340 Grade 420XF CR/HR	10%	11%	13%	15%
340-440	410	SAE J2340 Grade 340XF CR/HR	9%	10%	12%	14%
300-400	370	SAE J2340 Grade 300XF CR/HR	9%	10%	12%	14%
205-340	345	ASTM A1011 CS Type B (HR)	9%	10%	12%	14%
205-310	310	ASTM A1011 DS Type B (HR)	9%	10%	12%	14%
140-275	276	ASTM A1008 CS Type B (CR)	8%	9%	11%	13%
150-240	240	ASTM A1008 DS Type B (CR)	8%	9%	11%	13%
115-200	200	ASTM A1008 DDS (CR)	7%	8%	10%	11%

#### 4.6 PRESSURE PADS

- 4.6.1 All Pressure Pads are to be constructed of 4140-4150 steel non hardened plate or equivalent.
- 4.6.2 Minimum Pressure Pad thickness is 38mm.
- 4.6.3 Detail drawings for each Pressure Pad plate and windows are required. These drawings must be fully dimensioned. Inserts must include jack screw holes.
- 4.6.4 Pressure Pads must be retained with keeper blocks and/or standard size spools with 16mm bolts minimum. Spools should be the Locking style cap. Standard Lifters are acceptable for retention Only.
- 4.6.5 Spool must be accessible and removable without removing nitrogen units, parallels, etc., from the die.
- 4.6.6 Shoulder bolts may not be used for retaining Pressure Pads.

Adient  
NA Regional Supplier Standards Manual  
Tooling and Equipment  
Metal Stamping Dies – North American Tooling Standards

July 2025

---

- 4.6.7 Keepers are to be fixed with min. (2) 12mm bolts. For dies over 600 ton use a min. of (4) 12mm bolts.
- 4.6.8 Preferred square footprint on die shoe for keepers.
- 4.6.9 Pressure Pads should have window inserts allowing for removal of punches while the die remains in the press. If a punch can be designed to be removed without a window this is Preferred.
- 4.6.10 Flat windows may be pocketed into the Pressure Pad for location. Bolt & dowel hole pattern must be designed to prevent incorrect installation.
- 4.6.11 Contoured windows must be dowelled to the Pressure Pad for location.
- 4.6.12 Windows must have threaded jackscrew holes for removal (same thread as retaining screws) and face mounted in die.
- 4.6.13 Pressure Pads should be cleared out so punches can be shimmed 10mm minimum. No Shoulder Screws.
- 4.6.14 Clearance around punches through windows should be half product strip thickness.
- 4.6.15 Pressure Pad windows should be made from a 4140 steel and hardened. Do not make windows out of D2 or A2.
- 4.6.16 Working Pressure Pads with hardened form inserts must be guided with guideposts and bushings sufficient to properly contain them. They must also be heeled to upper die set. No trimming and Forming on the same Pressure Pad.
- 4.6.17 Cutting steels may not be mounted to Pressure Pads.

July 2025

---

- 4.6.18 Cams for piercing or trimming must have spring / nitrogen Pressure Pads at cutting interface. Fixed “bridge” “Hook” “finger” Pressure Pads are not permitted unless written approval at design review is signed by a Adient representative.
- 4.6.19 Urethane Pressure Pads are not permitted. Exceptions only allowed with written approval from Adient during design review.
- 4.6.20 Upper pad must have balancing blocks on lower tool to keep the pad level.
- 4.6.21 In the case of tools with deep extrusions, each stage of the extrusion must have a separate Pressure Pad insert. These may be mounted on a common Pressure Pad plate. The extrusion punches should be “Tough Head” headed (i.e. not ball lock) and the Pressure Pad window should be large enough to remove the punch holder in the press.
- 4.6.22 Standard Lifters are not to be used to guide Pressure Pads, they can be used for retention only.
- 4.6.23 Pressure pads retained with a foot under form steels must be 1 piece construction. No bolted-on feet are allowed.

#### 4.7 **Die Shoe Specifications**

- 4.7.1 Minimum thickness for all boiler plate die shoes shall be 75mm for lower die and 63mm for the upper die.
- 4.7.2 All Dies require Die Locators. For Transfer Dies and Dies going into 1000 Ton Presses or Larger Adient AME will provide CAD for what is required. For Dies going into Presses smaller than 1000Tons below illustrates requirements.

July 2025

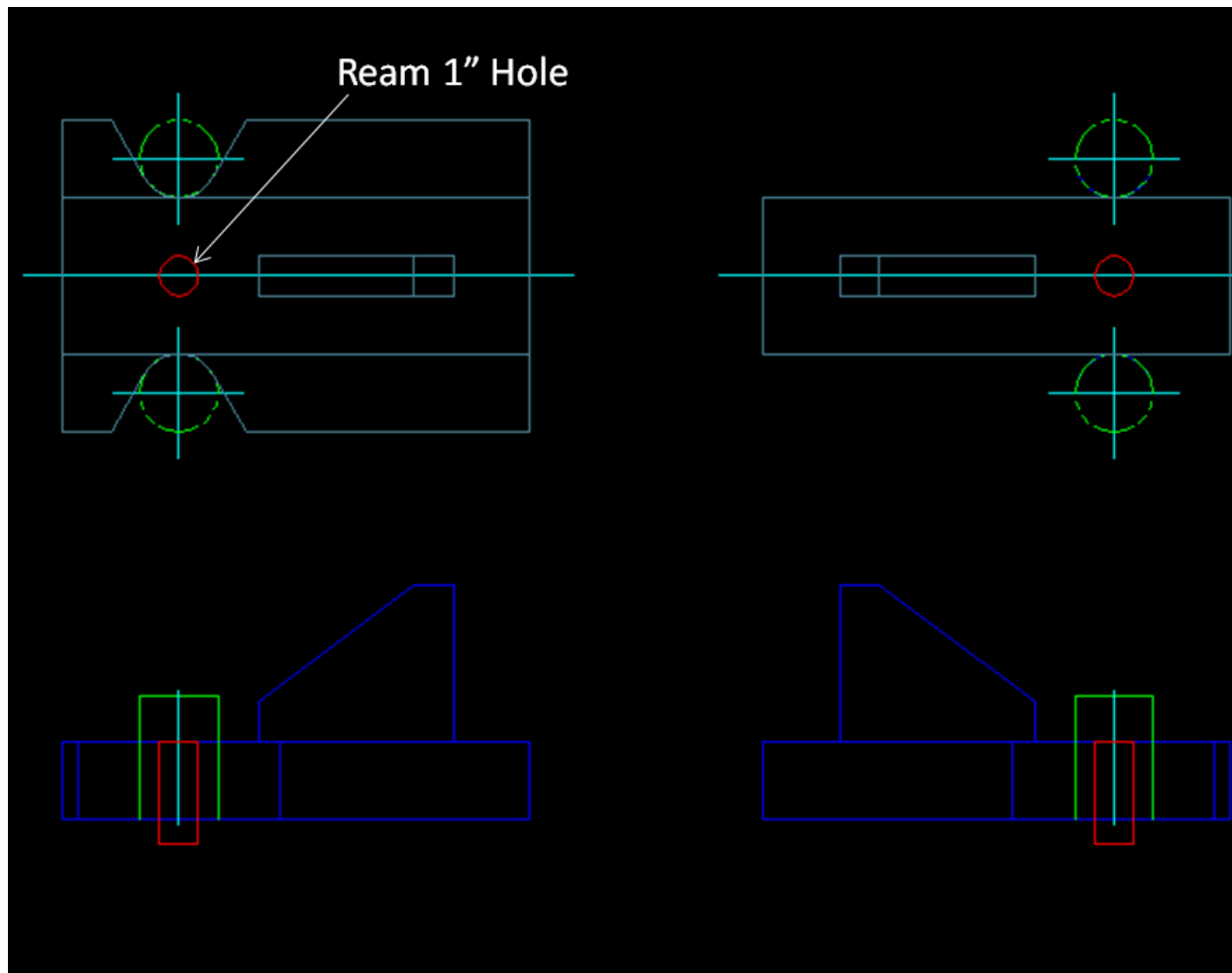

- 4.7.3 Each die set (sub-die) must have 4 guide pins with ball bearing guides. One post must be offset to avoid miss-assembly of the die. For dies in presses less than 400-ton use 50mm guide pins. Tools in presses 400-800 tons use 75mm guide pins. Tools in presses over 800 tons use 100mm guide pins.
- 4.7.4 Two post die sets will not be accepted, except in transfer conditions where bars need clearance, and only by specific Adient authorization at design review.
- 4.7.5 Ball cage guide pins to be used on dies 400 tons and below. Ball cages must be fully engaged before work starts in the tool.
- 4.7.6 Thrust blocks must be engaged before guide pins engage. Thrust blocks are to contain thrust they are not to be used to guide the upper die shoe. A .1mm gap should be present. Thrust blocks will be blued up during runoff and should not be contacting through the stroke of the Die.

Adient  
NA Regional Supplier Standards Manual  
Tooling and Equipment  
Metal Stamping Dies – North American Tooling Standards

July 2025

---

- 4.7.7 All dies will be equipped with handling lugs in accordance with the weight of the dies.
- 4.7.8 Cast die shoes are only allowed by special permission in writing from Adient. If approved, GM 238 is required for casting steel. Certification must be provided to Adient from the foundry. Special pattern review required on casting prior to foundry. No upper geometry may be cast into die shoe. Absolutely no cast cutting steels are allowed. See Casting Section for casting requirements.
- 4.7.9 All dies that will require over 300 working tons or any dies with off-balanced load must have bi-directional thrust blocks installed on the die set to minimize potential damage if the die is misfed. This is to be determined at the design review.
- 4.7.10 Guide Pins and Bushings to be retained with a Ring and 4 bolts, the hardware supplied with the Pins and Bushings is not to be used.
- 4.7.11 The minimum guide pin engagement will be 40 mm (see figure). A useful guide is as the contact length between guide bush-pillar when the tool starts to punch or trim. This applies to progressive and transfer tools.

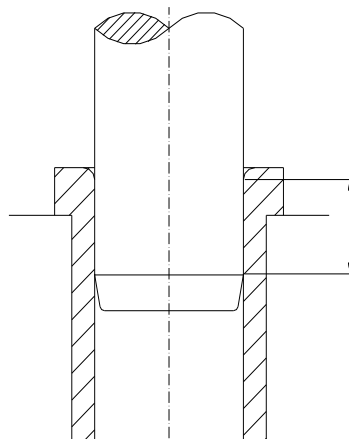

Minimum length 40 mm

July 2025

- 4.7.12 Standard for shut and feed-line heights (not including mounting plates)  
 All tools are to follow this standard for setting shut height and feed height

Group	Die Length	Shut Height	Feed Height
1	> 144"	40"	24"
2	60" - 144"	24"	14"

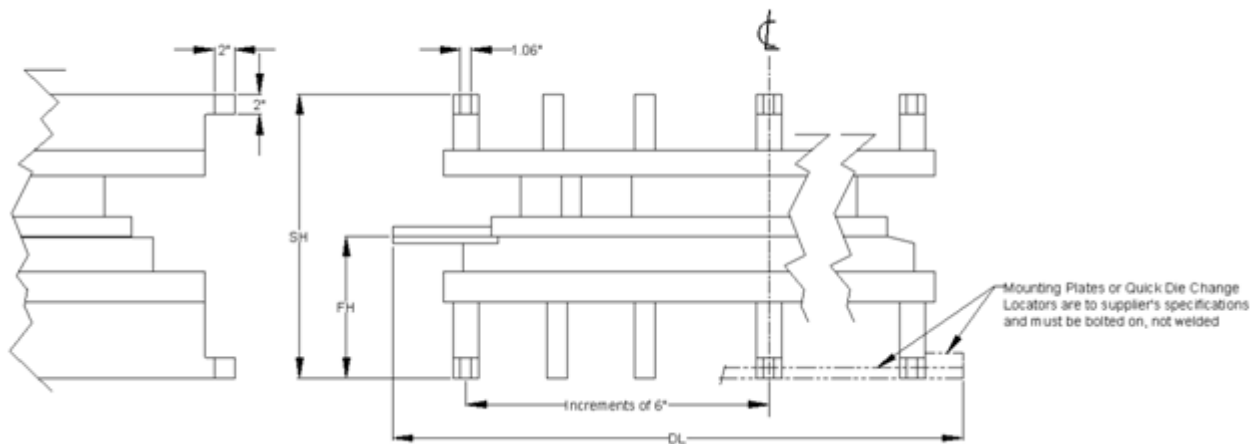

#### 4.8 Slug Clearance/Scrap Removal

- 4.8.1 Part and scrap cannot fall off the die at the same place, they must be separated.
- 4.8.2 Maximum slug size is 305mm long.
- 4.8.3 Provide through holes in the die shoe to remove all scrap and slugs produced in the tool. Trim steel should be supported directly under the Hardened Detail. Slug relief should be as much as possible through the die set without compromising integrity of the Hardened Detail.
- 4.8.4 Scrap guides or deflectors must be provided around all areas where slugs fall into the holes in the die shoe to avoid slugs collecting in the die.
- 4.8.5 Scrap chutes that deflect the scrap through the bolster or off the side of the bed must be part of the tool and must be supplied with the die. These

July 2025

---

scrap chutes must be bolted into the die and designed so the scrap does not pile up on any plates under or on the die. Requests for other types of scrap removal systems will be at the expense of the requestor. Maximum Angle should be used on Scrap Chutes to ensure slugs to not Pile up.

#### 4.9 Cams

- 4.9.1 All cams and cam slides must work on commercially available wear plates (Ampco 21 or similar) unless the cam design requires a dwell action. Steel on steel is acceptable with dissimilar materials coated; this must be approved by Adient in writing at design review.
- 4.9.2 All cams that form or require sensitive timing should dwell in the closed position to make the shut height of the press less critical.
- 4.9.3 All cam drivers should be the width of the cam working area when possible.
- 4.9.4 All cams should be guided by 3 Piece Cam Assembly and a rectangular key to ensure cam lines up properly. 3 Piece consists of a Post, Wear Plate for the Side of the Cam and Wear Plate for the Top of the Cam.
- 4.9.5 Cam Pierce Punches should be mounted to a Plate to accommodate adjustments of position. Similarly, the Cam Pierce Insert will be an Insert in a Pocket.
- 4.9.6 The Wear Plates under the Cam should cover the entire stroke of the Cam.
- 4.9.7 Cam Trim Punches should be supported where possible with a thrust block opposite the trim edge.
- 4.9.8 All cam pads (bottom surface) must be a minimum of 1.5 x height of the cam. This applies to Cam Drivers as well.

Adient  
NA Regional Supplier Standards Manual  
Tooling and Equipment  
Metal Stamping Dies – North American Tooling Standards

July 2025

- The base-to-height ratio on all cam drivers shall be 1.5 : 1.0 minimum.
- Provide 50 mm minimum wear plate engagement at initial contact with the working slide.
- Provide 2/3 minimum wear plate engagement below a plane projected from the front of the cam through driver surface on the slide, perpendicular to the driver surface.

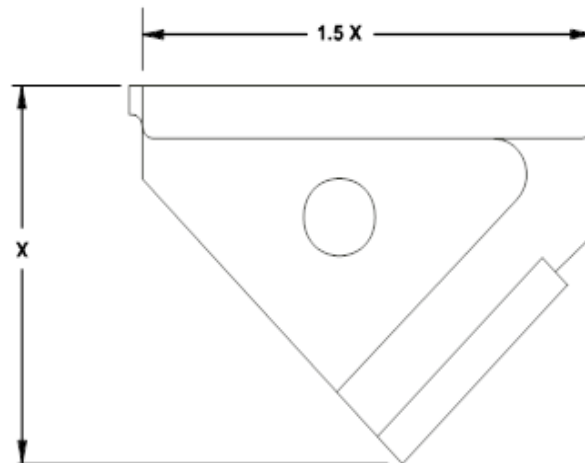

**TYPICAL DRIVER**

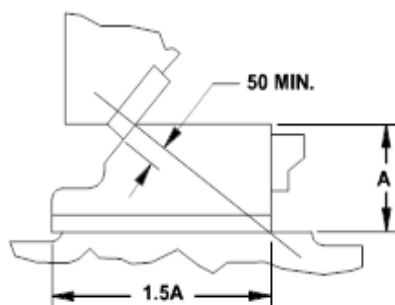

**INITIAL CONTACT**

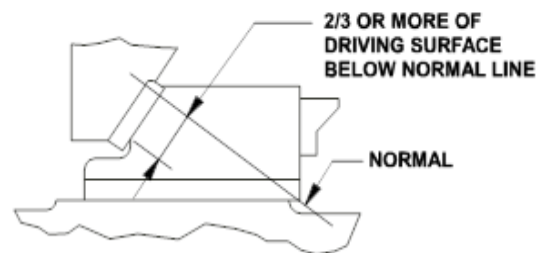

**CLOSED POSITION**

- 4.9.9 All movable sections and cams must have grease fittings and/or grease grooves for proper lubrication.

July 2025

---

- 4.9.10 Gag cams must be approved by Adient ATE's at design. Must be able to operate gag outside the die or be air operated. It must be clearly marked so the operator can identify the part number at the location of the gag. Instructions must be in place if multiple gags are used.
  - 4.9.11 Cams should be returned by nitrogen springs. A positive return should be added if possible, and if not, a return sensor must be added. No finger type cam returns. Any cam systems without positive returns/sensors must be approved by Adient at design review.
  - 4.9.12 If a hole is not pierced in press direction and True Position tolerance is less than 0.75mm, a cam must be used to achieve tolerance. If a surface profile zone is not in die plane and has a profile tolerance of 0.75mm or less, a cam must be used to restrike. If a trim line is not in die plane and has a profile tolerance of 0.75mm or less, a cam must be used to trim.
  - 4.9.13 Use commercial cam guide units if possible. Confirm type with Adient/CM at design review.
  - 4.9.14 All cam trim and pierce units must be removable in the press.
  - 4.9.15 Aerial cams not allowed unless authorized in writing by Adient.
  - 4.9.16 All Weld zones not on Die Plane must be Cam Trimmed. Trim Punch and Insert must be adjustable
- 4.10 **Springs and Nitrogen**
- 4.10.1 Hyson or Dadco nitrogen cylinders must be used for all dies.
  - 4.10.2 Cylinders are to have self-aligning rods and dynamic lubrication system.
  - 4.10.3 Manifold cylinder systems should utilize the non-breathing type of cylinder.
  - 4.10.4 Cylinder travel to be 90% of maximum cylinder travel.
  - 4.10.5 Die springs are not allowed except 1<sup>st</sup> hit pins.
  - 4.10.6 When the die is fully opened no preload must exist on the cylinders.

July 2025

---

- 4.10.7 All designs must use standard catalog cylinder sizes. If longer rod extensions are necessary, transfer pins or kiss blocks should be used between the pad and the cylinder rod.
- 4.10.8 All cylinders/springs must be fixed into the die shoe by individual screws or retainers.
- 4.10.9 Nitrogen cylinders in the lower die are to have drain holes for drainage of liquids.
- 4.10.10 All draw and forming stations must have nitrogen cylinders plumbed together as one unit or use a manifold. In other areas of the die where 3 or more cylinders are used together (i.e. lifter rails, pads) it must be discussed at the preliminary die design to determine if plumbing together is required. Dies with three or less cylinders must be easily accessible in press. Pressure Monitor sensor must be installed whenever Nitrogen cylinders are linked together
- 4.10.11 All manifolds and plumbed cylinders must have a gauge, quick release fill valve and drain valve (control panel) on the front of the die. Fill Valve must be accessible but protected from Damage.
- 4.10.12 Operating pressure of each manifold to be stamped adjacent to gauge on the die shoe.
- 4.10.13 Data sheets are required on all manifolds.

#### 4.11 Die Protection Sensors

- 4.11.1 All progressive dies must be designed and built with an end of die strip sensor (Misumi end of strip sensor), to verify that the strip has fed up completely without buckling in the die. The required sensor to be defined by the intended stamping facility before tool buy-off. The Tooling Supplier is responsible for providing the Bracket, the electrical Sensor will be provided by the Stamper.
- 4.11.2 Coil fed transfer dies require a Misumi style Pitch sensor at the end of the Strip. Sensor Bracket to be determined during Design Review.
- 4.11.3 All coil fed dies must be designed and built with provisions for a hard stop at the beginning of the die. An Anti-Pull Back Notch and Finger on the front side of the die at minimum is required.

July 2025

---

- 4.11.4 All sensors are provided by the Stamping Plant. (GLOBAL TOOLING SUPPLIER) is responsible to ensure the Grooves, brackets are in place for the sensor installation by the stamping plant. Any other Machining requested during design review for Sensor installation is the responsibility of the (GLOBAL TOOLING SUPPLIER).

#### 4.12 Stamp Information

- 4.12.1 The following information will be stamped on the front of the die shoe on the working face:
- 4.12.1.1 Vendors company name including address and phone number.
  - 4.12.1.2 Vendors job number to aid in ordering replacement sections.
  - 4.12.1.3 Adient/PS Tool Number (must obtain from Adient or PS who will receive tool)
  - 4.12.1.4 Part Number
  - 4.12.1.5 Material thickness, width, and pitch
  - 4.12.1.6 Weight of upper die (identified on upper die)
  - 4.12.1.7 Total weight of die (identified on lower die)
  - 4.12.1.8 Outside shut height
  - 4.12.1.9 Adient Tool Identification number (TA)
  - 4.12.1.10 OEM Tool Asset/Tag Number (separate tag)
  - 4.12.1.11 Year Tool was built
  - 4.12.1.12 Die Size Length, Width, Shut Height, Tonnage Required
- 4.12.2 Before the tool is shipped to the Adient stamping facility or PS, identify the owner of the tool and provide the proper "Property of" plate on the tool.
- 4.12.3 Removeable stamp information. Julian Date must be removeable when die is closed on the floor. Pressure Pad should be cleared to allow removal without opening the die. Example Picture Below.

July 2025

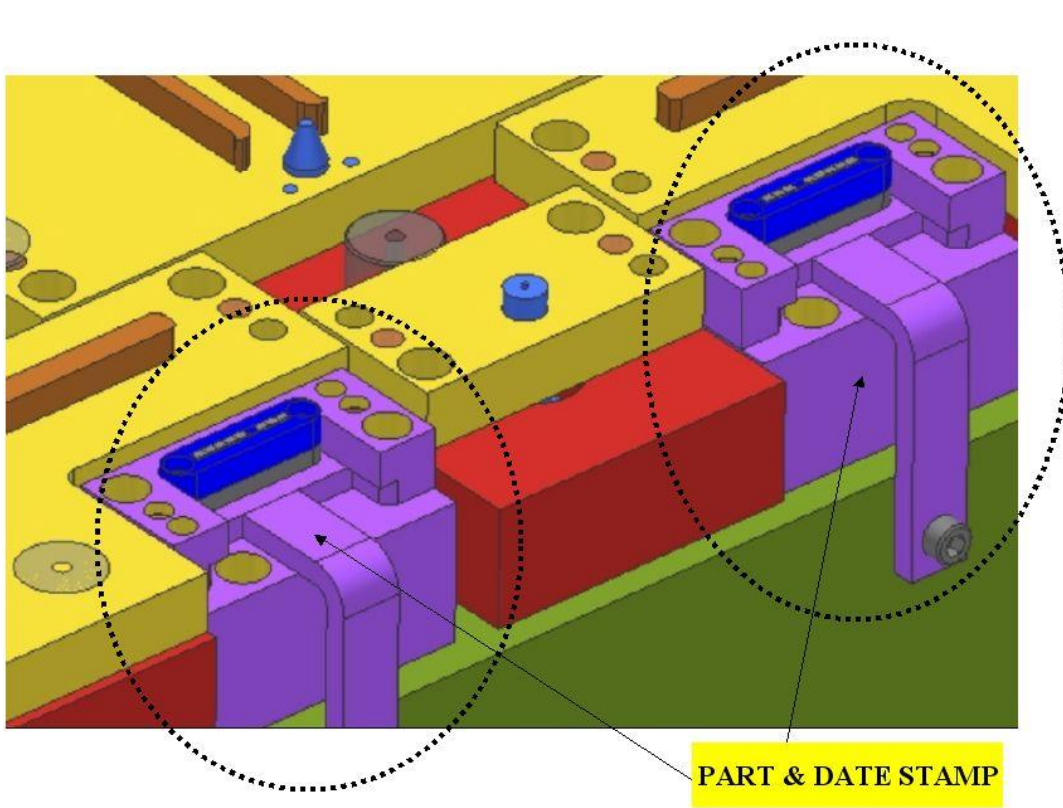

#### 4.13 Stop Blocks

- 4.13.1 All dies to have a minimum of four stop blocks.
- 4.13.2 Blocks must be a minimum of 50mm X 100mm Rectangle.
- 4.13.3 Stops to be manufactured to the exact inside shut height. Stop blocks to be grooved at the center 10mm wide and 1.25mm (0.050") deep.
- 4.13.4 No holes in the Die Set should contact the Stop Blocks
- 4.13.5 All stop blocks to be located between upper and lower parallels.
- 4.13.6 One safety pad area to be provided diagonally on each side of the die over a Parallel.

#### 4.14 Parallels

- 4.14.1 All parallels are to be ground top and bottom.
- 4.14.2 Proper feed line and shut height to be maintained on all dies per Figure 4.
- 4.14.3 Parallels used for clamping and locating must be dowelled or keyed to the die shoes and sub plates (if present).
- 4.14.4 Parallels must have slotted feet for clamping. Slots will be 28.5mm wide and 65mm long. The position of the upper and lower clamping slots must match the Adient/CM press specified.
- 4.14.5 Clamping flat area must be 100mm long by 100mm wide. Plates are allowed to be welded to the Side of the Parallels and machined to maintain the 100mm. Must be fully grooved and welded, welds will be inspected at buyoff.
- 4.14.6 Clamping height above press ram and bolster must be 50mm.
- 4.14.7 If feet are not outside the die-set periphery, 127mm clearance is required above the clamping surface, for both upper and lower die-set.
- 4.14.8 Parallels for dies 300 ton and over will be a minimum of 50mm thick.
- 4.14.9 Parallels for dies 800 tons and over will be a minimum of 62mm thick.
- 4.14.10 Bolts used for fastening Clamp parallels must be a minimum of 20mm diameter. Non-Clamping parallels can be 16mm.

#### 4.15 Transfer Tools

- 4.15.1 If clearance issues associated to guide pins are identified during the design reviews, resolution must be identified and signed off by Adient on the design review sign-off forms.
- 4.15.2 All transfer tools going to **Battle Creek** require lower change master plate. **This should be quoted as a Line Item for all Transfer Dies.**

Adient  
NA Regional Supplier Standards Manual  
Tooling and Equipment  
Metal Stamping Dies – North American Tooling Standards

July 2025

---

- 4.15.3 Master plate clamping areas are to be 50mm thick over an area of 100mm x 100mm, with slots 28.5mm wide.
- 4.15.4 Lower master plates must have locators to match the keys shown by the Adient/CM press specifications. Locators on master plate must be 4-way and 2-way (To be verified at design review.)
- 4.15.5 Lower plate thickness to be 62MM.
- 4.15.6 All sub-plates must be 4-way located to the die shoes with either keys or removable headed line-up pins. This is up to (GLOBAL TOOLING SUPPLIER) as to which type required.
- 4.15.7 4 way locating features required for parallel alignment to master plate and die sets.
- 4.15.8 Upper plates are not required. Upper die set is required to include die lifting mounting bars between parallels or “dog bone style” mounted to each upper die shoe. Upper parallels must include sensor block mounted on both sides of parallel to detect hydraulic clamp position.
- 4.15.9 Upper parallels to have clamping slots to match Adient/CM press specs.
- 4.15.10 Lower parallels and plates for dies going into 1000Ton Presses or larger will have 1680mm minimum span.
- 4.15.11 Preliminary die design must be submitted for a Kinematic Study after 50% review. All issues Identified during the Study must be corrected before 100% review. SPM should be Identified and be higher than Stampers minimum quoted SPM.
- 4.15.12 Each Transfer Station must have rough guides, that lead to pilots in tooling holes or trimmed edges of the part. Rough locators must be adjustable with the ability to tune within the press. Clearance must be provided in the opposite die shoe for the full range of adjustability on the rough locators. Rough guide locators must have a minimum of 25 - 40 mm lead in.
- 4.15.13 (GLOBAL TOOLING SUPPLIER) should recommend pilot locations after award if not present in part design. The location(s) of the pilot holes must be submitted and approved by Adient Engineering. Scrap areas can be used for Piloting, holes that get pierced out larger in the later stations can be used as well.

July 2025

---

- 4.15.14 Lifters need to be designed to allow the part transfer system to repeatedly pick up the part to achieve the required SPM. Upper die ejectors should be vertically above the lower lifters so that the part lifts squarely. Upper ejectors should have radii, so the part does not stick to them. Ejectors (lower pin gas spring) must be serviceable in press.
- 4.15.15 All Transfer Fingers are to be Grippers, Norgren. Shovels are not to be used.

#### 4.16 Lifting & Handling

- 4.16.1 Die must have two places between parallels wide enough for lift fork to carry or make special carrying handles on each end of the die. Exact dimensions and positions to be confirmed at design review. Example For Adient Athens plant dies that weigh over 4 tons should have forklift access places 215mm wide and 95mm min height, spaced 432mm min to 1400mm max between centers.
- 4.16.2 Tooling components between lower parallels should be protected from damage with rigid blocks.
- 4.16.3 Identification of fork access points to be painted on the die shoe.
- 4.16.4 All dies to be equipped with eight (8) tapped holes, (4) lower and (4) upper, for handling in accordance with the weight of the dies and positioned so the pick-up point on the crane to hold die at the center of gravity. All lift taps must be metric. Identify the hole size next to each hole.
- 4.16.5 24-3.00mm mm tapped holes are required for dies under 4,536kg and 36-4.00mm tapped holes for dies 4,536kg and over.
- 4.16.6 80mm minimum hole depth.
- 4.16.7 Thread size must be stamped beside holes.
- 4.16.8 Tie straps are required for locking the die for shipping.
- 4.16.9 All dies with change plates must include “dog bone” lifters balanced for the die center of gravity.
- 4.16.10 Die handling devices must not impede the removal of scrap.

July 2025

---

#### 4.17 **Tonnage**

- 4.17.1 The Adient presses monitor all (4) corners of the press for tonnage. Therefore, the die must not overload any one corner of the press to successfully complete Buy-off. Configuration of tonnage is critical at die process review

#### 4.18 **Casting Requirements**

- 4.18.1 All castings, iron or steel, that are 90mm or thicker should be cored. It is essential to eliminate any large masses wherever possible by proper coring and ribbing. Design all outer casting walls 40mm thick. Design all inner tie ribs 30mm thick up to 500mm high. Ribs over 500mm high will be 40mm thick.
- 4.18.2 Design cores to uniform sizes where practical.
- 4.18.3 Cores should not exceed 400mm in the plan view in any direction.
- 4.18.4 Cores should not be smaller than 100mm X 100mm.
- 4.18.5 Design cores from the top or bottom wherever possible. Use side cores as a last choice.
- 4.18.6 For large, open-ended cores, consider the use of an “L” shaped wall to add strength to the pattern and casting.
- 4.18.7 Core depths should not exceed 2 ½ times the plan view nominal width. 1 ½ times the width is recommended. If depth exceeds 1 ½ times the width, foundry cleanup cores must be added to ribs/walls.
- 4.18.8 Add lightening cores where possible.
- 4.18.9 Lower die rough shelf thickness to be 87mm minimum, 75mm finished for all working areas.
- 4.18.10 Design all castings for optimized pattern milling accessibility.
- 4.18.11 Inside corners of all cores to have 25mm radius min. Features not to be shown in design and are to be provided by pattern source.
- 4.18.12 Outside corners of ribs on rough cast edges to have 5mm radii or 5 x 45° chamfer.

Adient  
NA Regional Supplier Standards Manual  
Tooling and Equipment  
Metal Stamping Dies – North American Tooling Standards

July 2025

---

- 4.18.13 Pattern source to provide a 15mm X 45° cast bevel around the outer edges of the base of all die shoes. Do not provide them on the inside edges of press fastening slots.
- 4.18.14 Pattern source to provide a 10mm X 60° bevel on all ribs that contact the bolster or slide.
- 4.18.15 Pattern source to provide a 10mm X 45° bevel all around the bases of all cast components that weigh 100lbs or more.
- 4.18.16 Vent holes to be added to all draw and hard form stations.
- 4.18.17 Add ribs behind areas with thrust.
- 4.18.18 Viewing holes for Scrap drop should be added to the Front and Back of the Die.

July 2025

Figure 1

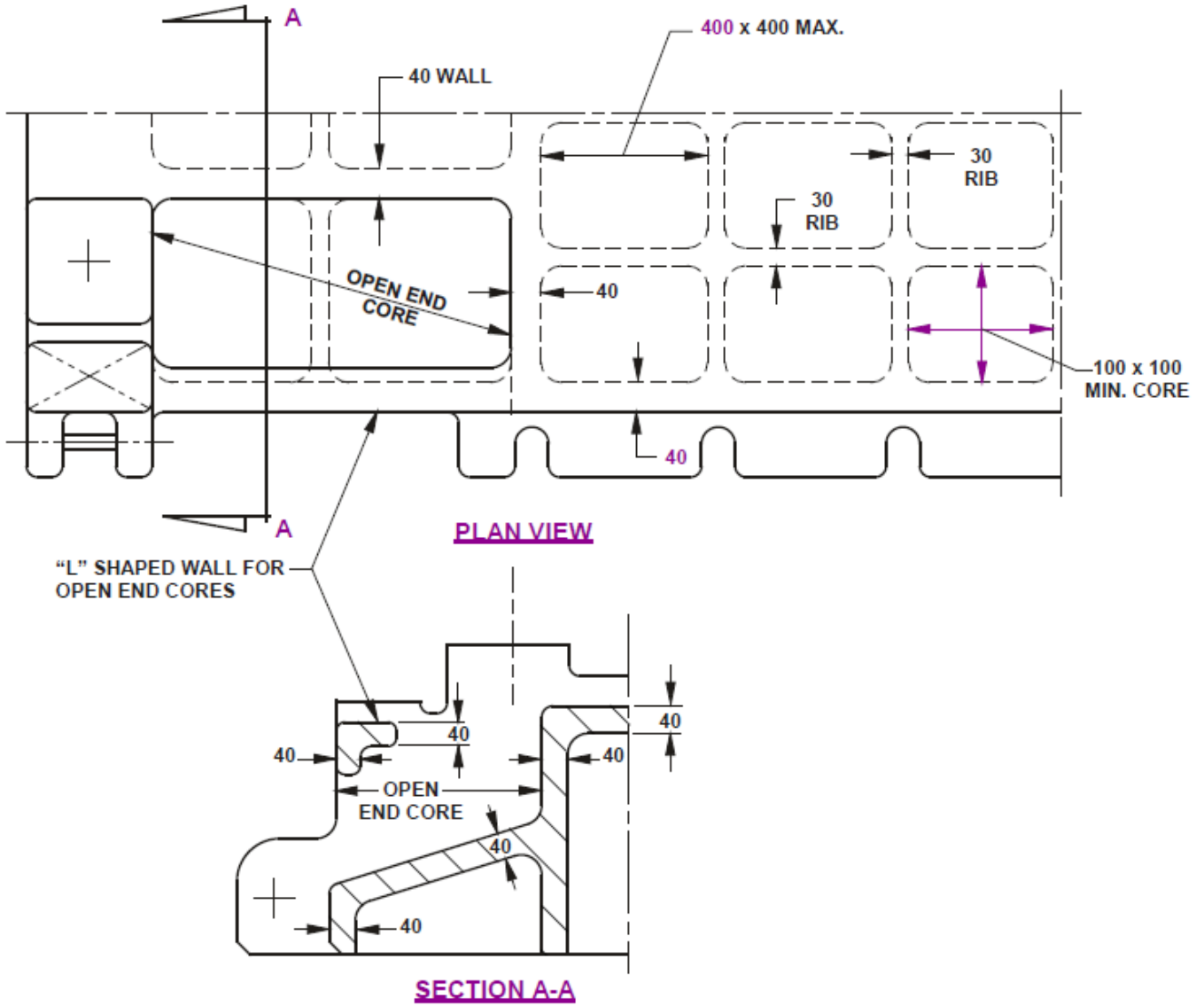
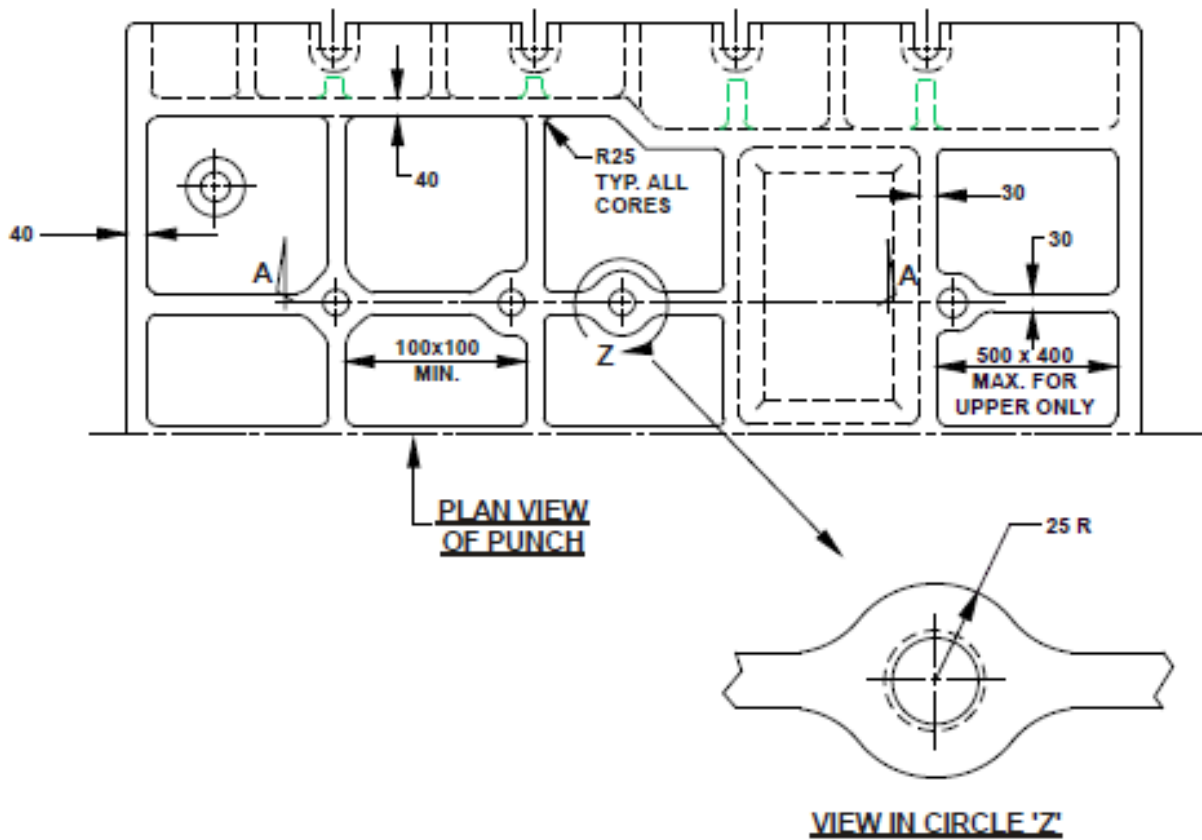
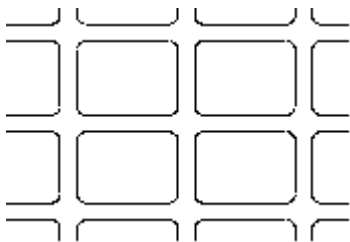

Figure 2

July 2025



**FIGURE 3**



NOT CORRECT

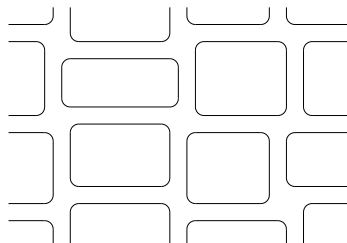

CORRECT

### Rib Location

The ribs must have an irregular position where possible. This results in greater strength.

July 2025

---

CASTING CONTINUED  
FIGURE 4

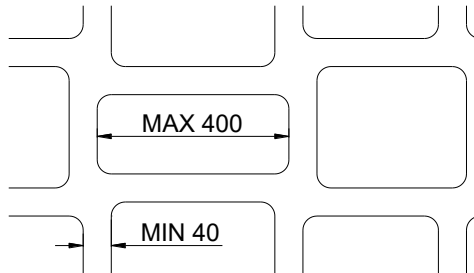

**Rib Sizes**

The minimum width of the inner ribs must be 40 mm in cast iron (GG25, 30, etc.). In the case of cast steel, the width can be smaller.

The distance between two ribs in the general structure must be 400 mm (maximum).

July 2025

---

**4.19 Athens Specific Die Standards**

4.19.1 TBD

**4.20 Battle Creek Specific Die Standards**

4.20.1 TBD

**4.21 Ramos Specific Die Standards**

4.21.1 TBD

**5 BUY OFF AT VENDOR**

- 5.1 Upon Adient ATE and Quality personnel approval of the (6) piece dimensional layout the die buy-off may be scheduled. Die buy-off procedures are notated in the Adient Buyoff Book
- 5.2 Buyoff material Supplied by Adient
- 5.3 Part must pass the Attribute Gage 100%
- 5.4 CMM Layout part must be restrained on datums, same as attribute check fixture.
- 5.5 300 strokes must be run in a continuous mode using coil fed system. Transfer Dies Hand Transferred Under 1 Ram. If Dies are unable to be under 1 Ram Shut Heights of the Dies must be verified and be the same.
- 5.6 The intended stamping supplier's material lube must be used during tool run-off. Lube specification will be supplied by stamping source upon request from the (GLOBAL TOOLING SUPPLIER).
- 5.7 Die is to be opened for inspection after 300-piece run-off at (GLOBAL TOOLING SUPPLIER) location. This may require the tool to be disassembled.
- 5.8 Six (6) pieces dimensional CMM layout to product print per quality measurement plan. This must be provided and approved by Adient/CM before buy-off visit is scheduled.
- 5.9 Max scrap length 305mm for all tools unless otherwise agreed to during design review and noted on Design buyoff sheet. When bypass cutters are used, scrap must fall each stroke.
- 5.10 Scrap must not accumulate more than 5 strokes on all other trimming or piercing operations and fall away freely from the die once the wear land is passed.
- 5.11 Screws must remain tight after the run, or corrective action must be taken.

Adient  
NA Regional Supplier Standards Manual  
Tooling and Equipment  
Metal Stamping Dies – North American Tooling Standards

July 2025

---

- 5.12 The buy-off check (i.e. Adient Regional Stamping Die Tooling Standards) sheet must be completed by the vendor and submitted to the Adient ATE before the tool is to be run-off.
- 5.13 Final Die Designs with all modifications completed during Development, Adient Buyoff Book., All Sign off sheets are to be submitted to Adient ADX portal at the completion of Vender Buyoff.

**6 Buy-off requirements at Adient/CM facility:**

- 6.1 Tools must operate 90 mins. at rate in full auto. Stops not attributable to die issues are allowed.
- 6.2 The 90 mins. requirement may be reduced at the discretion of Adient
- 6.3 Parts must fit quality gage 100%.
- 6.4 (6) piece dimensional CMM layout to product print per quality measurement plan. Will be completed after the Run; any issues are the responsibility of the GVT to correct before final sign off
- 6.5 A minimum Cpk of 1.67 must be achieved on a 30-piece sample on all SC's and CCs as identified on the drawing. If dimension has stop sign with an A, 300 pieces across the stamping check fixture can be used in-lieu of a 30-piece capability

Adient  
NA Regional Supplier Standards Manual  
Tooling and Equipment  
Metal Stamping Dies – North American Tooling Standards

July 2025

---

study.

- 6.6 Scrap must fall each stroke on any scrap cutter.
- 6.7 Scrap must not accumulate more than 5 strokes on all other trimming or piercing operations and fall away freely from the die once the wear land is passed.
- 6.8 Screws must remain tight after the run, or corrective action must be taken.
- 6.9 Final Die buy-off requires receipt of 100% updated cad die design along with BOM and detail prints received through ADX before the runoff
- 6.10 If additional lube is required throughout the tool, oiler and oil lines must be permanently installed in the tool (nozzle type per plant requirement).

## 7 TRACK CHANGES

- 7.1 **4.5.9** Pierce punches less than twice material thickness are not allowed. It is the (GLOBAL TOOLING SUPPLIER)'s responsibility to review the Adient product design to ensure this standard is not violated. REMOVED 2/10/2026
- 7.2 4-15-15 All Transfer Fingers are to be Grippers, Norgren. Shovels are not to be used. Added 2/10/2026
- 7.3 4-3-34 A Pressure Monitor sensor must be installed whenever Nitrogen cylinders are linked together. Added 2/10/26
- 7.4 4-10-10 Pressure Monitor sensor must be installed whenever Nitrogen cylinders are linked together Added 2/10/26